

Panther

THORN

96294675 PANTHER 1500 LED E3 OP RD WHI TC

RoHS	IP65	IK10			650 °C	T _a 0 +30
------	------	------	---	---	--------	-------------------------

Panther

A round bulkhead LED luminaire. Fixed output LED driver with 2 hour, manual test, emergency lighting circuit. Body: white polycarbonate. Diffuser: opal polycarbonate. Class I electrical, IP65, Impact strength: IK10. Complete with switchable tri-colour 3000K, 4000K, 5700K LEDs.

Dimensions: Ø285 x 100 mm
Weight: 1.3 kg



TLG_PANTNZ_F_RDWH.jpg

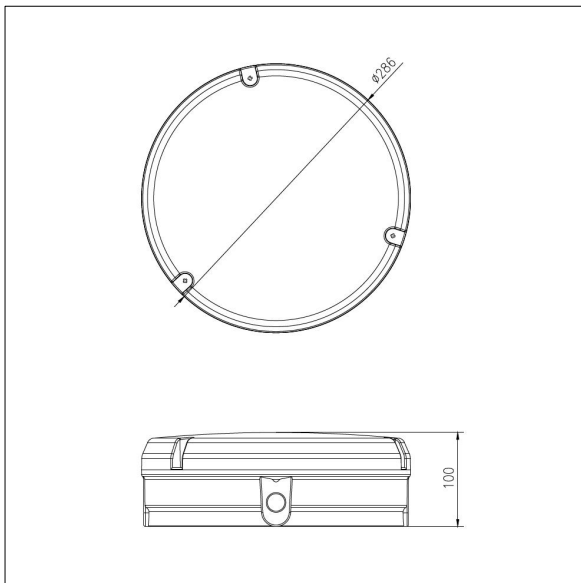

TLG_PANTNZ_M_RD.wmf

All values marked with an * are rated values. Thorn uses tried and tested components from leading suppliers, however there may be isolated instances of technology-related failures of individual LEDs during the rated product lifetime. International standards set the tolerance in initial flux and connected load at ±10%. Unless stated otherwise, the values apply to an ambient temperature of 25°C.

Thorn Lighting is constantly developing and improving its products. The right is reserved to change specifications without prior notification or public announcement.
© Thorn Lighting