

## Panther

### 96294651 PANTHER 1500 LED OP SQ BLK TC

RoHS	IP65	IK10			650 °C	T <sub>a</sub> -20 +40
------	------	------	--	--	--------	---------------------------

## Panther

A square bulkhead LED luminaire. Fixed output LED driver.  
 Body: black polycarbonate. Diffuser: opal polycarbonate.  
 Class I electrical, IP65, Impact strength: IK10. Complete  
 with switchable tri-colour 3000K, 4000K, 5700K LEDs.

Dimensions: 255 x 255 x 100 mm

Weight: 1.1 kg



TLG\_PANTNZ\_F\_SQBK.jpg

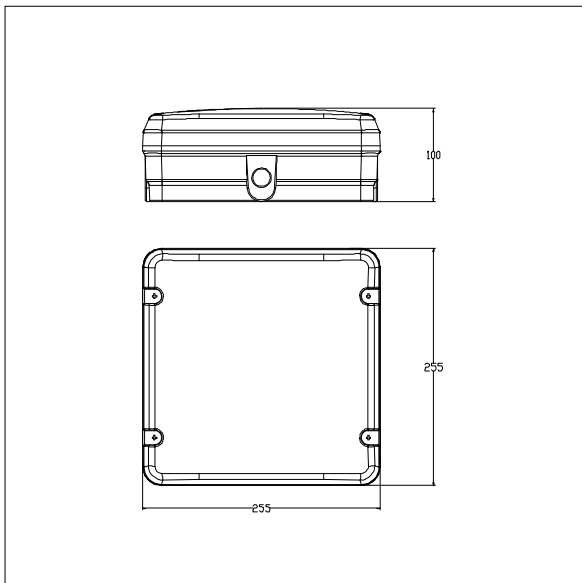

TLG\_PANTNZ\_M\_SQ.wmf

All values marked with an \* are rated values. Thorn uses tried and tested components from leading suppliers, however there may be isolated instances of technology-related failures of individual LEDs during the rated product lifetime. International standards set the tolerance in initial flux and connected load at  $\pm 10\%$ . Unless stated otherwise, the values apply to an ambient temperature of 25°C.

Thorn Lighting is constantly developing and improving its products. The right is reserved to change specifications without prior notification or public announcement.  
 © Thorn Lighting

**Panther**

**96294651 PANTHER 1500 LED OP SQ BLK TC**

**THORN**