

# THORN

LIGHTING

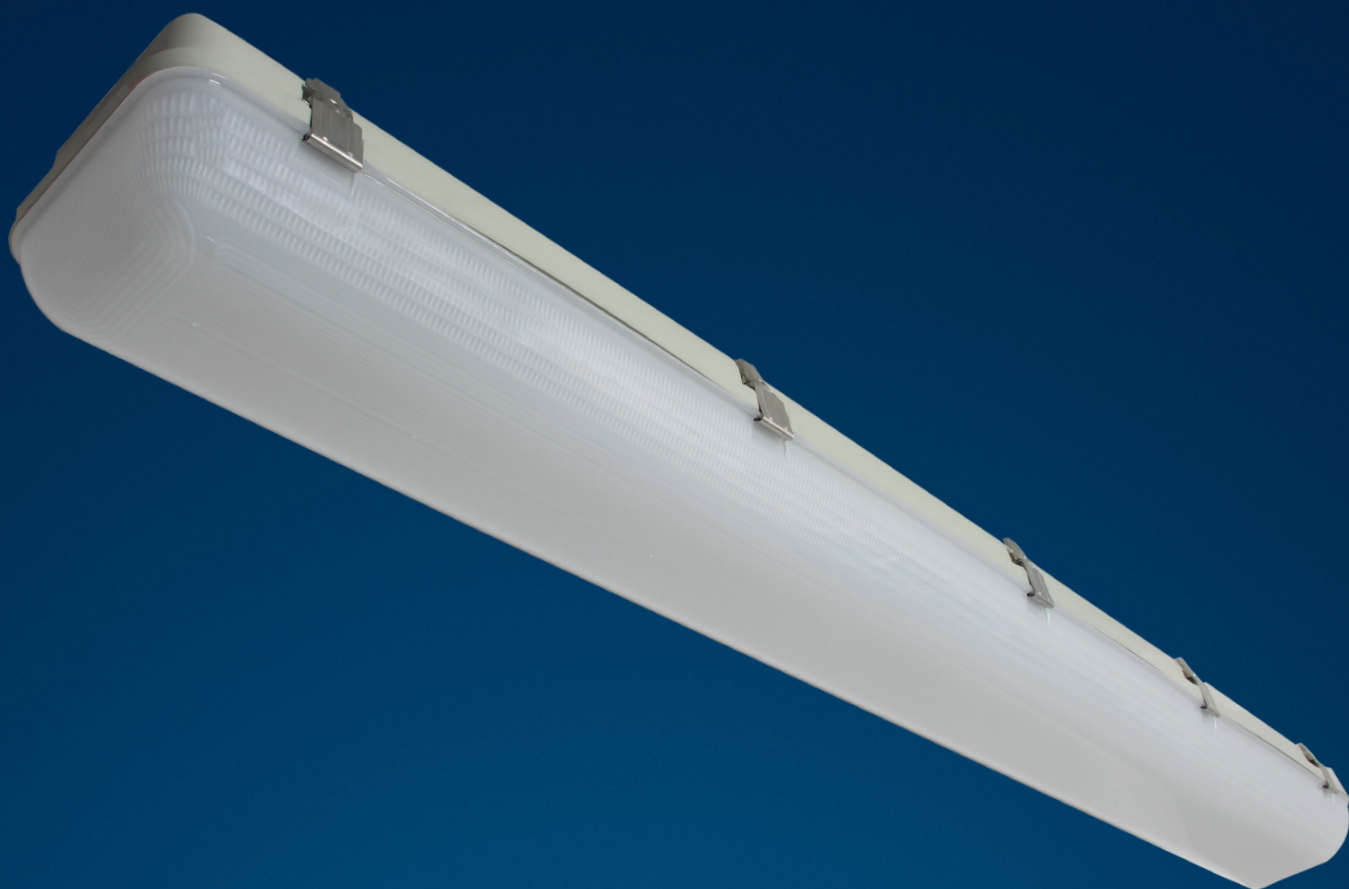

# WEATHERFORCE G2

Wide body moisture and dust-resistant LED luminaire

ZUMTOBEL Group Member

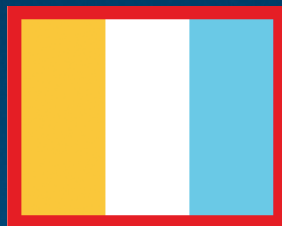
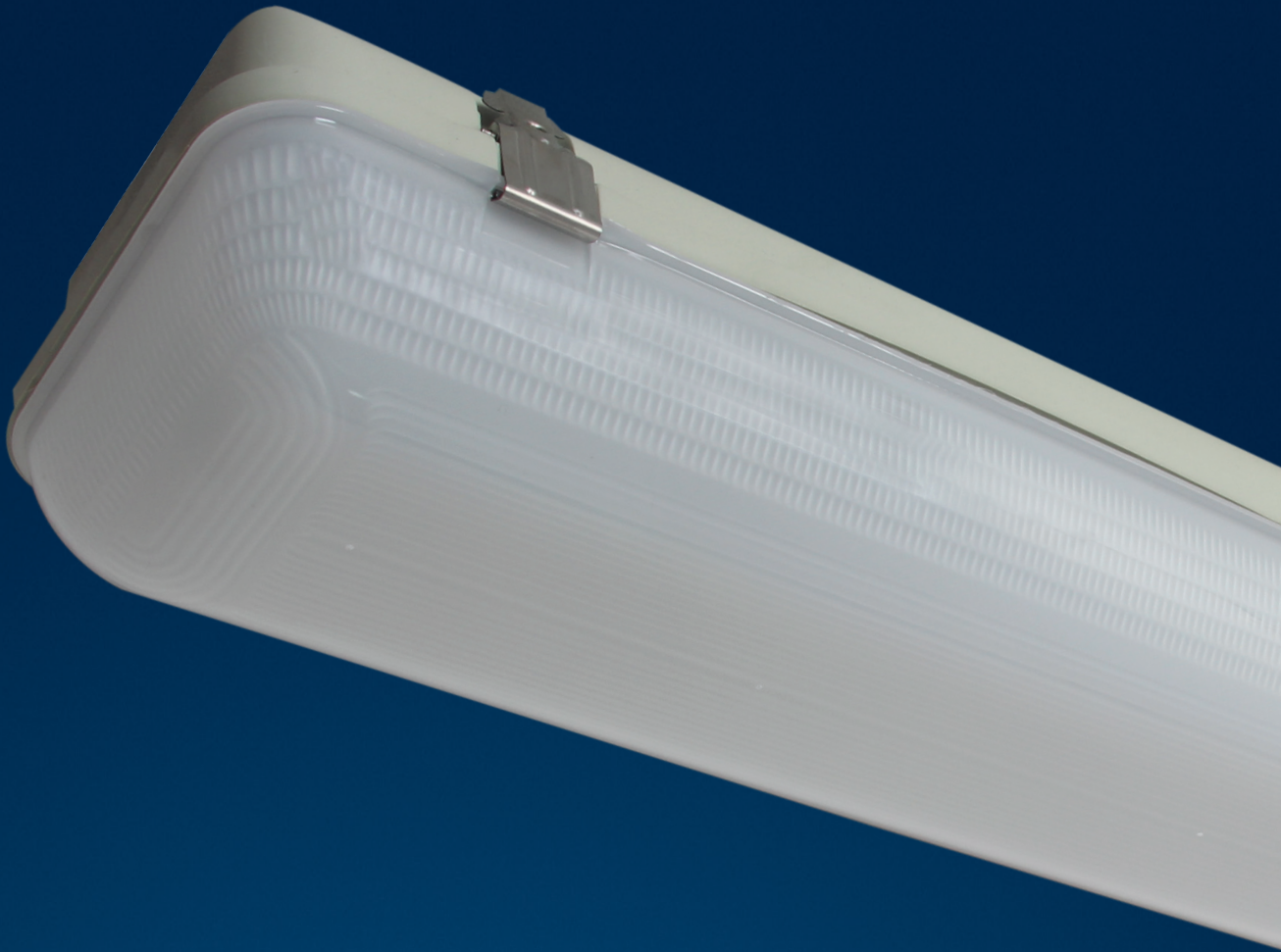

## **VARIO TECHNOLOGY**

Switchable light colour enables choice of colour output during installation.

This feature drastically saves stock space and aids in fulfilling the customer requirements

# THORN



## **WEATHERFORCE G2 ENGINEERED FOR HIGHER STANDARDS**

The Weatherforce G2 will assist with improving difficult installations, challenging environments, tight time schedules. With its highly versatile and extremely durable concept, the new IP65 WeatherForce G2 is here to help deal with whatever comes your way.



# WEATHERFORCE G2

THORN

Wide body moisture and dust-resistant LED luminaire

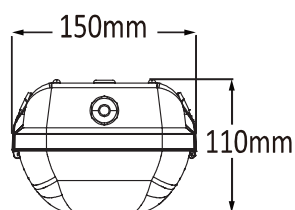

## Tridonic DALI driver option

The range offers one4all drivers with DALI-2 DT 6, switchDIM and corridorFUNCTION.

Dimming range 1 to 100%.

## Wide body batten (150 mm)

This wide body fitting is the perfect solution for every refurbishment project.

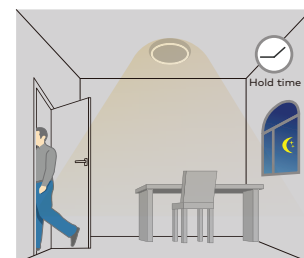
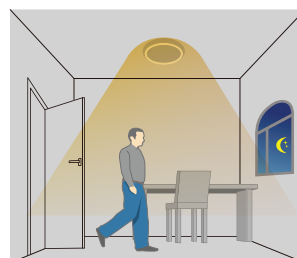
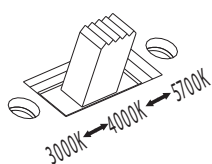

## VARIO technology

Switchable light colour permits to choose the colour output during installation.

It drastically saves stock space and assists in fulfilling the Customer preference.

## MicroWave Sensor option

With Corridor Function capability; after last detection, the light will be dimmed down to the stand-by dimming level after hold time and it will switch-off after the standby time.



## Emergency Lighting option

2 hours autonomy with AS/NZS 2293 classification.



# WEATHERFORCE G2

THORN

Wide body moisture and dust-resistant LED luminaire



A wide body, linear, water resistant LED luminaire, specifically designed for general outdoor applications.

DALI dimmable LED driver option with 2 hour emergency lighting option; in accordance with AS2293.3 Emergency Classification.

Available with:

- Microwave sensor and daylight hold-off and corridor functions.
- Class I electrical, IP65, Impact strength: IK08.
- Body: light grey injection moulded polycarbonate, supplied with tamper resistant screws.
- Diffuser: opal polycarbonate.
- Gear Tray: sheet steel, powder coated white.

WeatherForce G2 is able to be surface mounted or suspended. Complete with switchable light colour temperature 3000K - 4000K - 5700K LED.



WT (KG) ORDER NUMBER

#### Standard version

WF G2 LED2500 830-57 L6 HF	1.63	96650051
WF G2 LED5500 830-57 L12 HF	2.9	96650052
WF G2 LED6500 830-57 L15 HF	4.4	96650053

#### DALI dimming version

WF G2 LED2500 830-57 L6 HFI	1.73	96650054
WF G2 LED5500 830-57 L12 HFI	3.02	96650055
WF G2 LED6500 830-57 L15 HFI	4.5	96650056

#### Emergency Lighting version

WF G2 LED2500 830-57 L6 HFI E2	1.93	96650057
WF G2 LED5500 830-57 L12 HFI E2	3.25	96650058
WF G2 LED6500 830-57 L15 HFI E2	4.7	96650059

#### MicroWave Sensor version

WF G2 LED2500 830-57 L6 MWS-COR	1.85	96650060
WF G2 LED5500 830-57 L12 MWS-COR	3	96650061
WF G2 LED6500 830-57 L15 MWS-COR	4.5	96650062

830-57 = CRI>80 & CTT switchable light colour 3000K-4000K-5700K, HFI = DALI dimming, Corridor Function and SwitchDim, E2 = Emergency 2 hrs, MWS-COR = MicroWave Sensor with Corridor Function, L6 = 660mm, L12 = 1270mm, L15 = 1570mm

## POLAR DIAGRAM

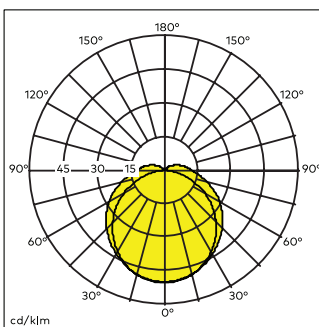

96650052 WF G2 LED5500 L12

## DIMENSIONS

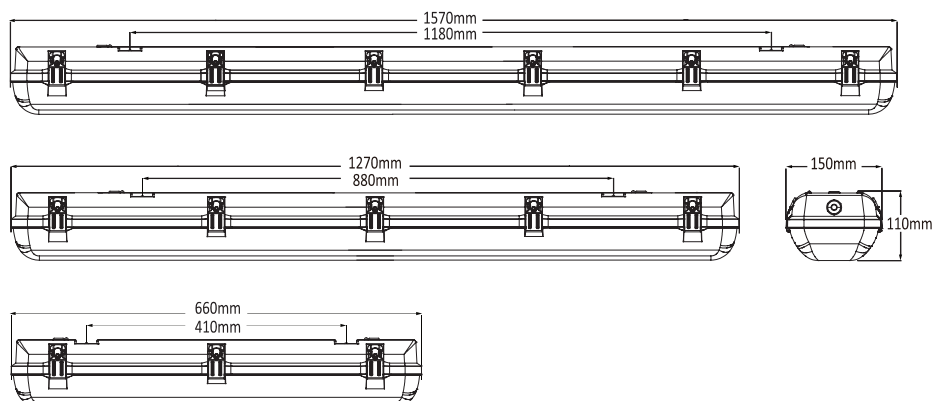

# WE MAKE LIGHT WORK

## ZUMTOBEL Group

### NSW - HEADQUARTERS

ZG Lighting Australia Pty Ltd  
2/7 Millner Avenue  
Horsley Park, NSW 2175  
T +61 1300 139 965  
F +61 (0) 2 9625 1500  
info.au@zumtobelgroup.com

### NSW

Showroom & Light Forum  
ZG Lighting Australia Pty Ltd  
306 Pacific Highway  
Crows Nest, NSW 2065

### VIC

ZG Lighting Australia Pty Ltd  
163 Epsom Road  
Flemington, VIC 3031

### QLD

ZG Lighting Australia Pty Ltd  
Level 1, 349 Coronation Drive  
Milton, 4064 QLD

### TAS

Watts Lighting  
U4/4 Higson Street  
Midway Point, TAS 7171

### SA

LEDA Lighting Solutions  
3 Prescott Court  
Hallett Cove, SA 5158

### WA

SCOPE LIGHTING Pty Ltd  
14 Christable Way  
Landsdale, WA 6065

### NT

Global Lighting Solutions Pty Ltd  
Cnr Mataram Street &  
Coonawarra Road  
Winnellie, NT 0820

### AUCKLAND - HEADQUARTERS

ZG Lighting (NZ) Limited  
27 Jomac Place,  
Avondale, Auckland 1026  
New Zealand  
T 0800 800 834  
T +64 (9) 828 7155  
F +64 (9) 828 7591  
info.nz@zumtobelgroup.com

### WELLINGTON

ZG Lighting (NZ) Limited  
Level 2, 225 Thorndon Quay,  
Pipitea, Wellington 6011  
New Zealand  
T 0800 800 834  
T +64 04 815 8010  
F +64 04 499 6058

### CHRISTCHURCH

ZG Lighting (NZ) Limited  
Unit 7A, 303 Blenheim Rd  
Upper Riccarton, Christchurch 8041  
New Zealand  
T 0800 800 834  
T +64 03 366 2485  
F +64 03 366 8905