

EN	Installation Instructions	HR	Uputstvo za montažu	SE	Installationsanvisning
DE	Montageanleitung	NL	Montagehandleiding	RU	Инструкция по монтажу
CZ	Montážní návod	RO	Instructiuni de montaj	SRB	Instrukcija za instalaciju
DK	Monteringsvejledning	IT	Istuzioni di montaggio	SK	Montážny návod
EE	Paigaldusjuhend	LT	Montavimo Instrukcijos	SLO	Navodilo za montažo
FI	Asennusohje	LV	Instalācijas instrukcija	CN	安装说明书
FR	Notice de montage	NO	Monteringsanvisning		
HU	Szerelési útmutató	PL	Instrukcja montażu		



1. Installation and commissioning may only be carried out by authorised specialists and wired in accordance with the latest IEE electrical regulations or the national standards.

2. Mains power must be switched off before carrying out installation.

3. The manufacturer, shall not be liable for any damage resulting from inappropriate modifications to the luminaire or faulty installation.

4. Caution, risk of electric shock.

The control gear provides basic insulation between the LV supply and the control circuit.

5. Luminaires not suitable for covering with thermally insulating material

6. Wall mounting in either vertical or horizontal position is also acceptable



You can help protect the environment!

Please remember to respect the local regulations: hand in non-working electrical equipment to an appropriate waste disposal centre. The packaging material is recyclable. Dispose of the packaging in an environmentally friendly manner and make it available for the recyclable material collection service.

Product Description	SAP Code	Wattage	Current	Voltage	PF	CRI	Ta	CCT
PANTHER 1500 LED OP RD WHI TC	96294648	15W	0.135A	220-240V	>0.5	>80	-20-40°C	3000K/4000K/5700K
PANTHER 1500 LED OP RD BLK TC	96294649	15W	0.135A					
PANTHER 1500 LED E3 OP RD WH TC	96294675	17W	0.14A				0-30°C	
PANTHER 1500 LED E3 OP RD BLK TC	96294676	17W	0.14A					

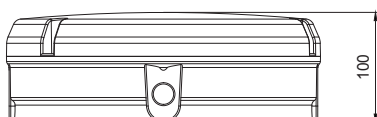
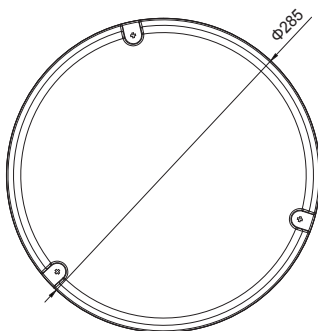

1	x4
2	x4
3	x4
4	x4

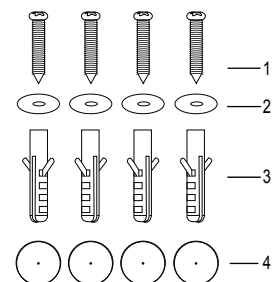

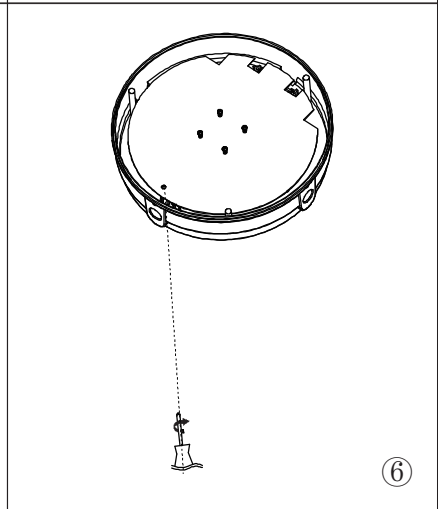
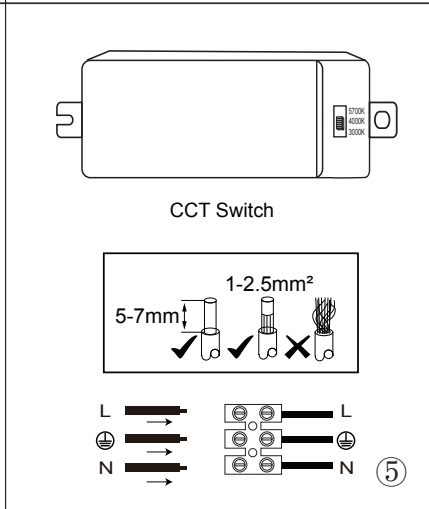
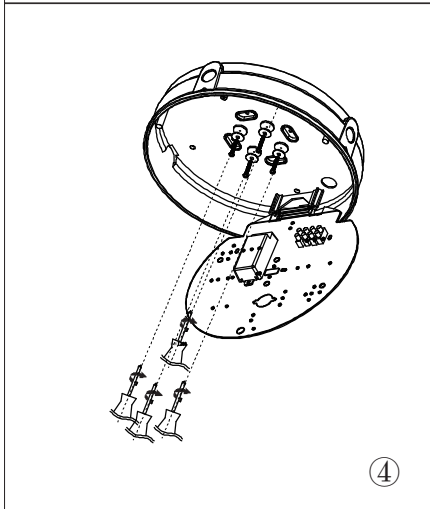
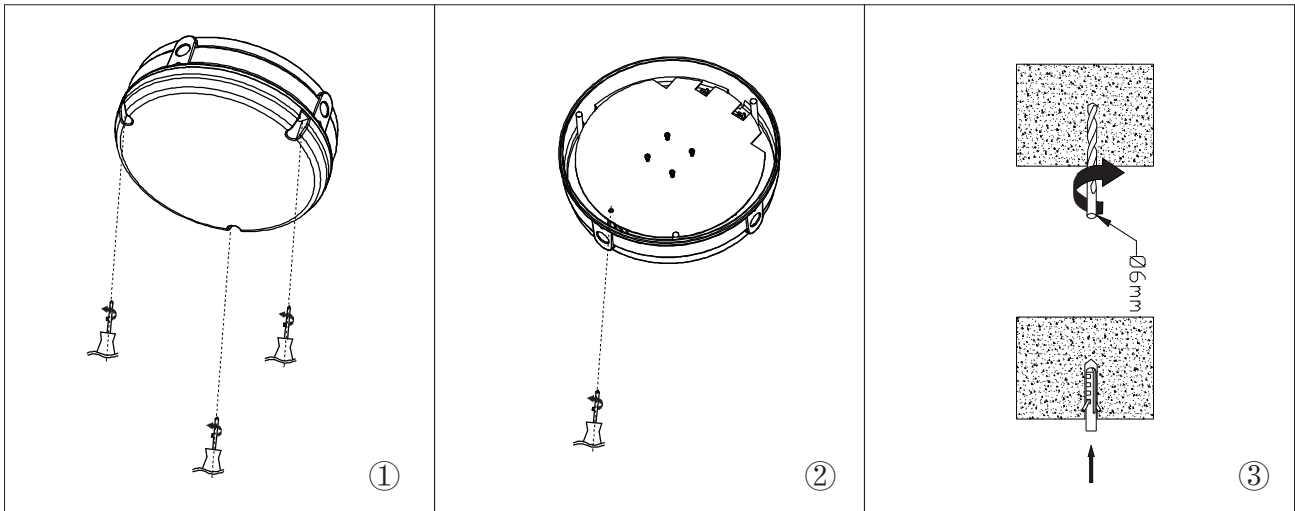

## Emergency E2 models (AS/NZS 2293)

1. Ensure the battery plug is connected to the socket on the driver

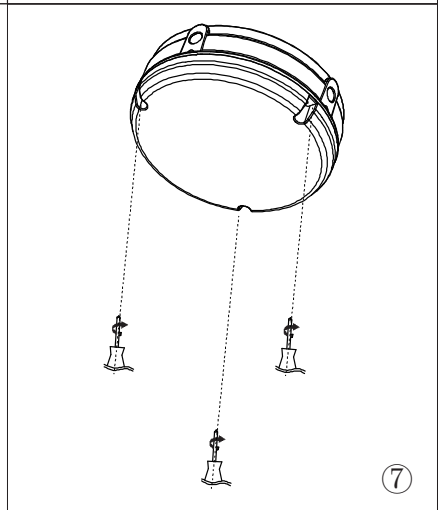
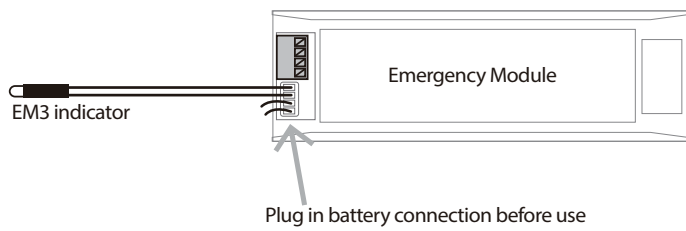

2. Make the electrical connections to the terminal block according to the markings:

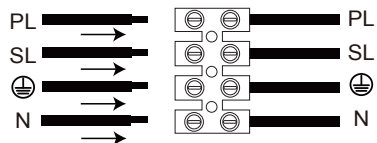
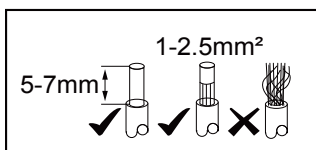

3. Connect to power supply and allow to charge for 24 hours.