

UK Installation instructions
DE Montageanleitung
CZ Montážní návod
DK Monteringsvejledning
EE Paigaldusjuhend

FI Asennusohje
FR Notice de montage
HU Szerelési útmutató
IT Istruzioni di montaggio
LT Montavimo Instrukcijos

LV Instalācijas instrukcija
NO Monteringsanvisning
PL Instrukcja montażu
SE Installationsanvisning
RU ИНСТРУКЦИЯ ПО МОНТАЖУ

FRANCAIS

-Remplacer toute protection fissurée.
 -Les luminaires classe II doivent être installés de façon à ce que la partie métallique ne soit pas en contact avec l'installation électrique connectée à la terre.

ATTENTION: Les luminaires classe I doivent être reliés à la terre.

-Ce luminaire fonctionne à une tension nominale qui doit être coupée avant toute intervention sur l'appareillage.

-Toute modification de cet appareil est interdite.

-Respecter la distance minimale par rapport aux objets éclairés définie par ce sigle :

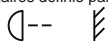

SVERIGE

-Ersätta alla spräckta skyddsplåtar.
 -Klass II armaturer måste installeras så att nakna metalldelar i armaturen inte är i kontakt med någon elektrisk installation, kopplad till en skyddledare.

WARNING: Klass I armaturer måste vara jordade.

-Denna armatur fungerar med högspänning som måste vara fränslagen före ingripande i driftdonen.

-Alla ändringar i denna armatur är förbjuden.

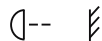

ITALIANO

-Sostituire sempre tutte le protezioni danneggiate.
 -Gli apparecchi in classe II devono essere installati in modo che le parti metalliche non siano in contatto con apparati elettrici collegati a terra.

ATTENZIONE: Gli apparecchi in class I devono essere collegati a terra.

-Questo apparecchio funziona a tensione nominale, questa deve essere interrotta prima di ogni intervento sul gruppo di alimentazione.

-Ogni modifica dell' apparecchio è proibita.

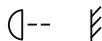

ENGLISH

-Replace any cracked protective shield.
 -Class II luminaires must be installed so that exposed metal work of the luminaire is not in contact with any part of the electrical installation connected to a protective conductor.

WARNING: Class I luminaires must be earthed.

-This luminaire operates at mains voltage which must be switched off before intervention in control gear.

-Any modification to this luminaire is forbidden.

-Lighted objects nearer than the minimal distance in the is forbidden

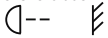

DEUTSCH

-Ersetze jede gebrochene Schutzscheibe.
 -Schutzklasse II Leuchten müssen so installiert werden, daß berührbare Metallteile nicht mit einem, an dem Schutzleiter angeschlossenen Teil der elektrischen Installation in Kontakt kommen können.

ACHTUNG: Schutzklasse I Leuchten müssen geerdet sein.

-Diese Leuchte wird mit Netzspannung betrieben. Bevor Eingriffe am Vorschaltgerät vorgenommen werden sowie vor Wartung und Installation, ist die Versorgungsspannung abzuschalten.

-Jede Änderung an dieser Leuchte ist verboten

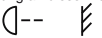

SUOMI

-Rikkoontunut suojalasi vaihdettava välittömästi uuteen vastaavaan.
 -Asennettaessa suojausluokan II valaisinta on peruseristetyin johdon ja koskettavien metalliosien välinen kosketus tehokkaasti eristettävä.

VAROITUS: Suojausluokan I valaisin täytyy maadoittaa.

-Verkköjännite on kytkettävä pois ennen valaisimen huoltotoimenpiteitä.

-Valaisimen rakennetta ei saa muuttaa.

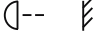

AREA1 36L

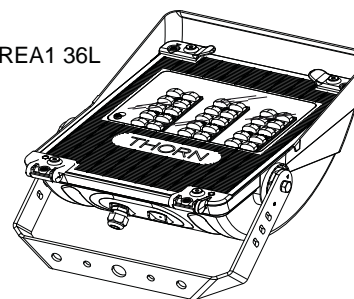

AREA2 60L-84L

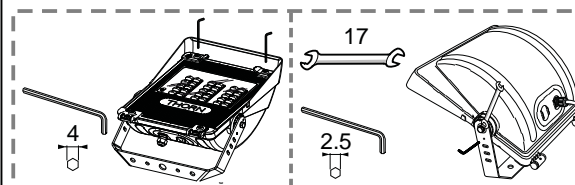
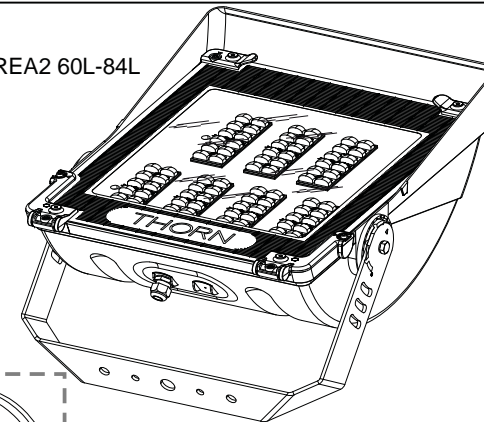

LED CLASS I CLASS II IP66 IK08 CE

AREA1

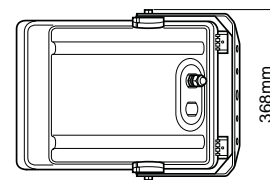
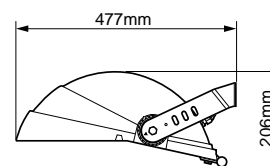

AREA2

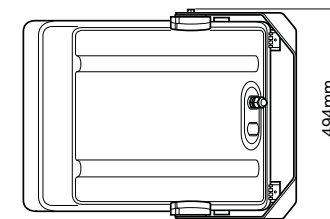
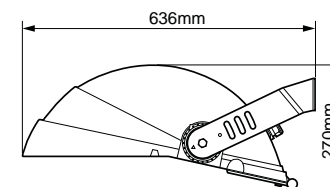

	AREA1	AREA2
SCX	0,05m ²	0,09m ²
	0,2m ²	0,34m ²
	0,06m ²	0,09m ²
	9 kg	19,2kg

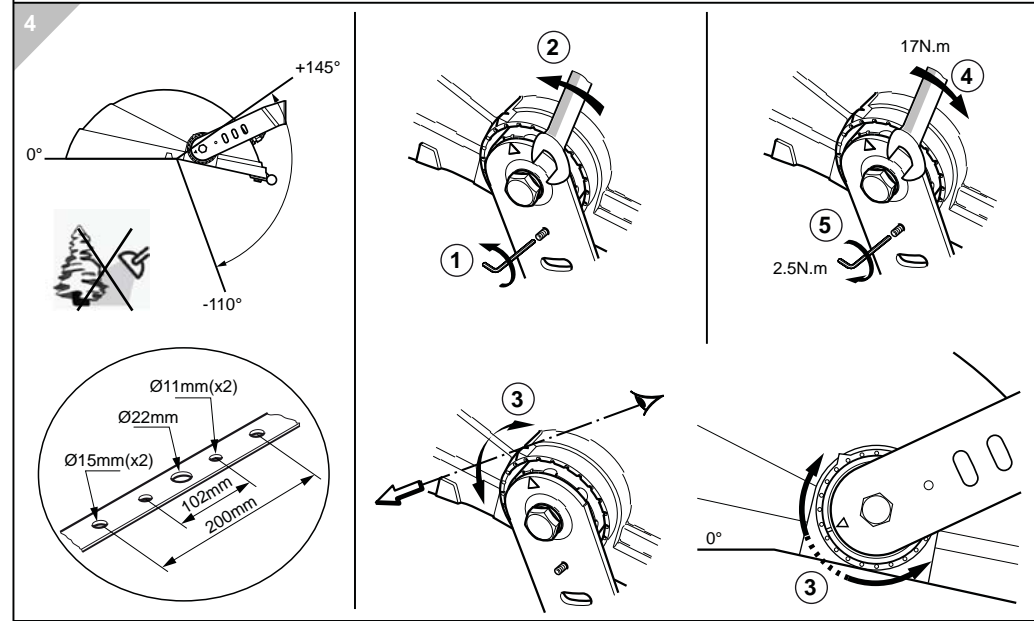
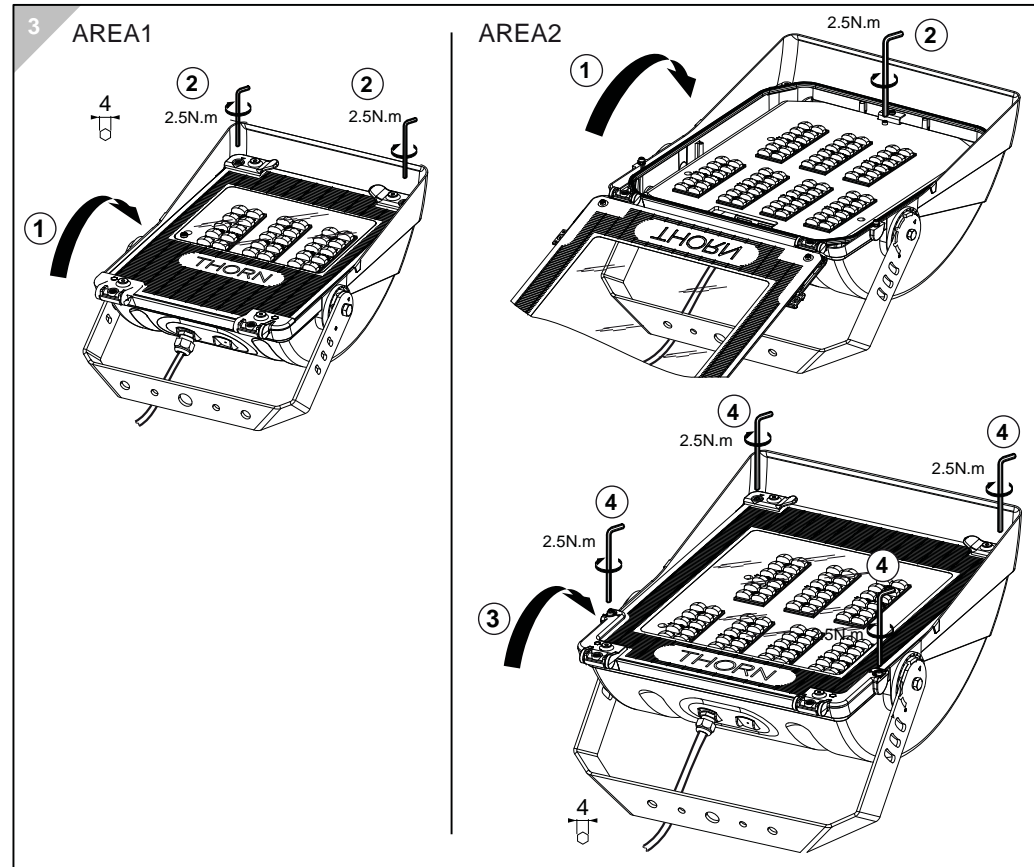
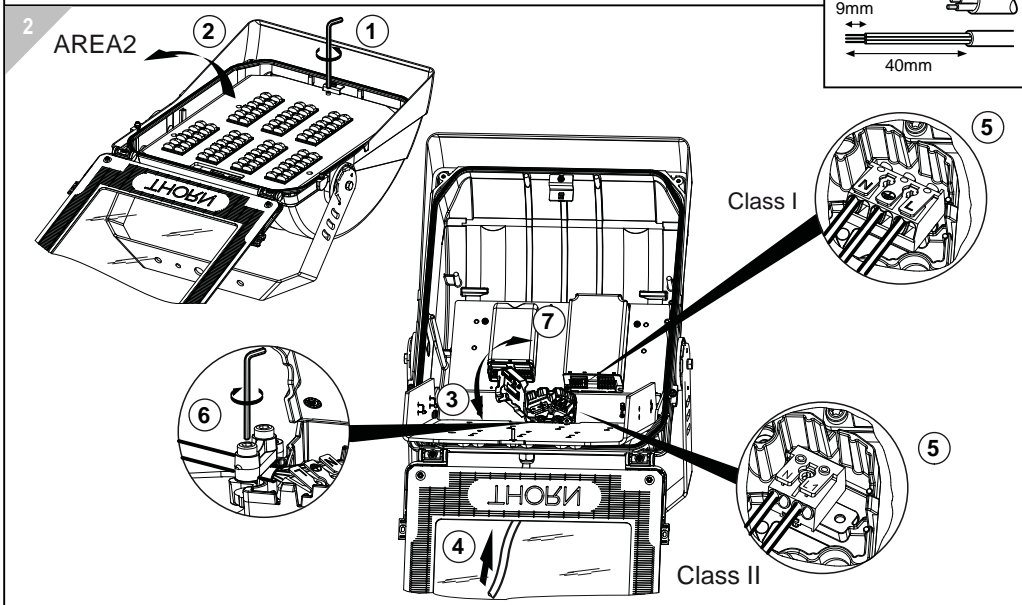
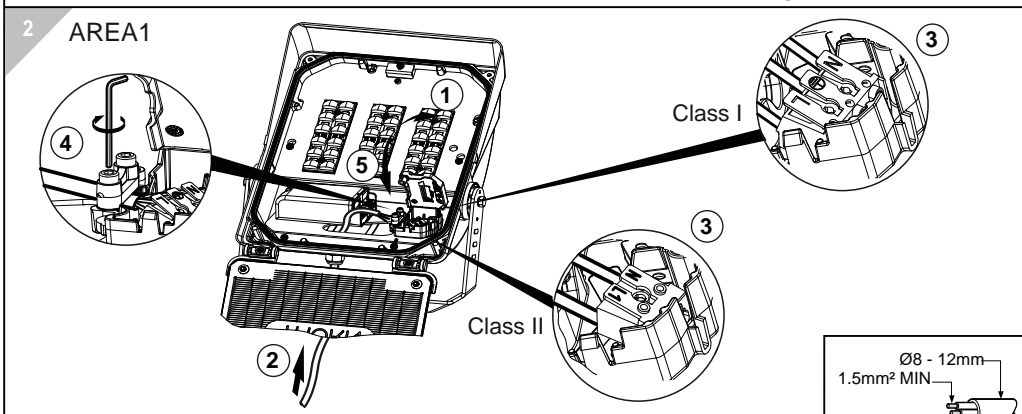
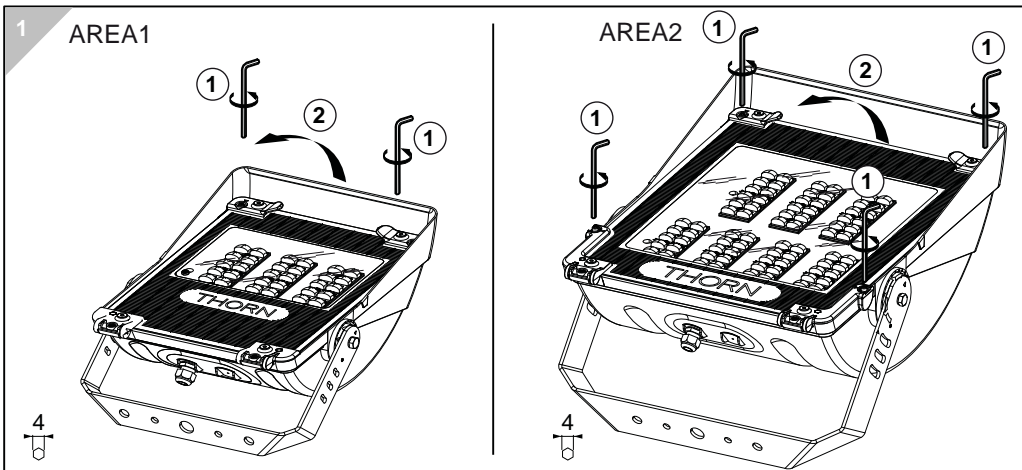

Maintenance and disassembly instruction sheet
Entretien et feuille d'instruction de démontage
Underhålls- och demonteringsinstruktion

